

Dual Gas Transmitter

E2660-CO-NO2



Features

- CO and NO₂ detection in underground garages
- Two analog outputs 4-20 mA and 0-10 V
- RS485 Modbus RTU digital interface
- Wall mount IP65 protected housing

Specifications

	CO	NO ₂
Sensor type	Electrochemical	Electrochemical
Sampling method	Diffusion	Diffusion
Detection ranges	0...300 ppm / 0...1000 ppm	0...20 ppm / 0...200 ppm
Max. overload	2000 ppm	100 ppm 1000 ppm
Resolution	1 ppm	0.1 ppm 1 ppm
Response time T90	ca. 30 s	< 60 s <40 s
Maintenance interval	12 months	6 months
Sensor lifetime	> 10 years	> 2 years
Signal update	Every 1 second	
Self-diagnostics	Full functionality check at start-up	
Warm-up time	≤ 1 min	
Power supply	12 ... 36 VDC (default) 24 VAC or 230 VAC as options	
Power consumption	< 2 VA	
Digital interface	RS485, Modbus RTU protocol	
Analog outputs	2 × 4-20 mA / 0-10 V, user settable	
Output scale width	Recommended: 20-100% of the range; > 10 × resolution in any case	
Enclosure	Grey ABS plastic, wall mount, protection class IP65	
Dimensions	H90 × W145× D55 mm	
Sensor heads	M25	
Remote sensor probe	Protection IP65, shielded cable default cable length 3.0 m	
	NOTE! Remote probe with an electrochemical sensor have to be installed in the same environmental conditions as the entire product to ensure correct measurements *This rule does not apply to remote probes with other sensor types. *This rule does not apply to electrochemical sensors, if sensor is attached (wall-mount version)	
Operating conditions	Explosion-safe areas; Non-aggressive atmosphere without condensation; 0,9...1,1 atm; -20...+50 °C, 0...85 %RH NOTE! we offer technical solutions for extreme humidity, please contact us for details.	



Dimensions

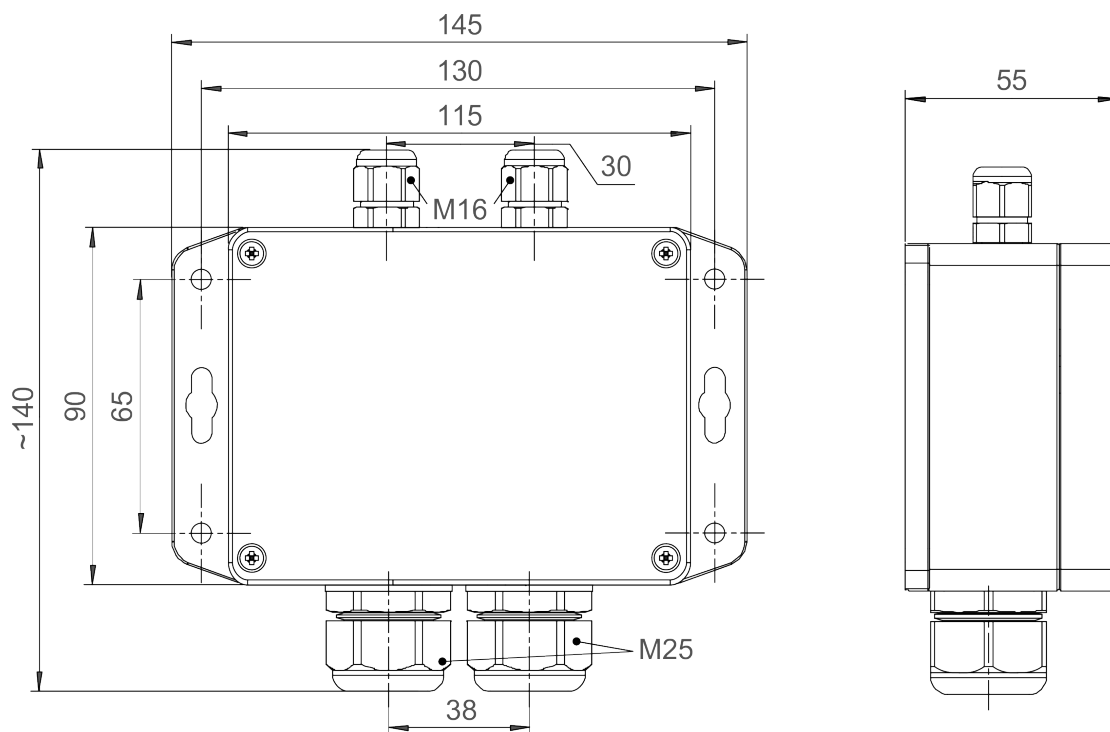

Connection diagram

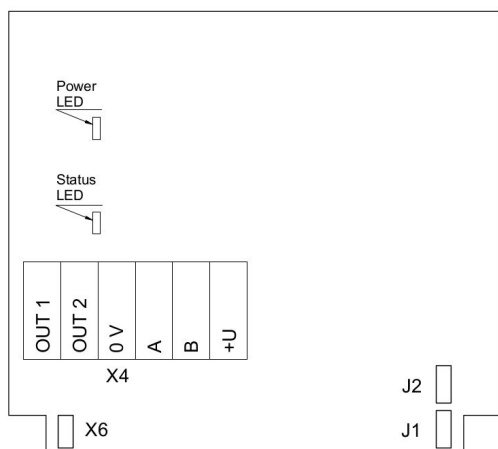

Version without PSU and relays

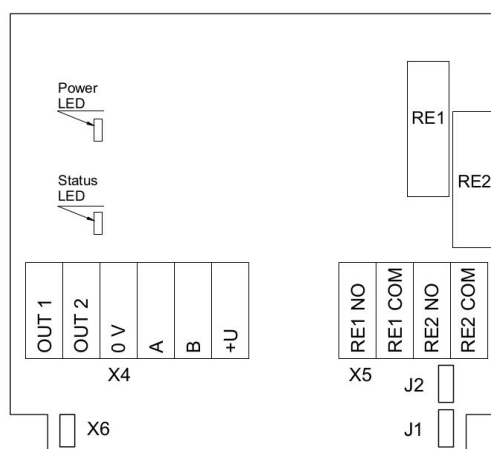

Version without PSU and with relays

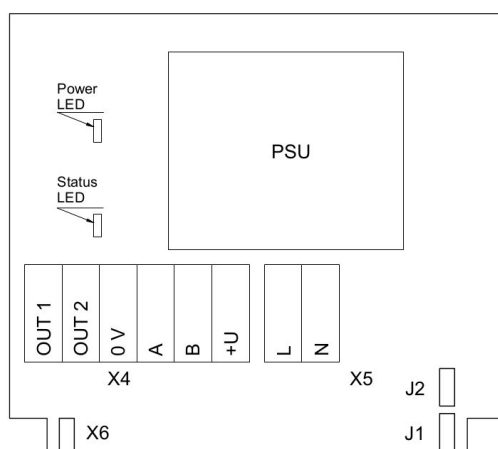

Version with PSU and without relays

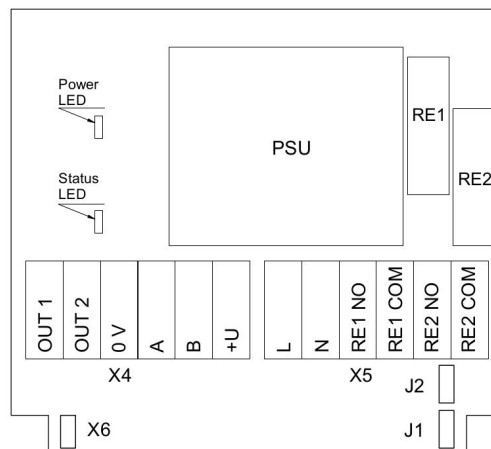

Version with PSU and relays

Jumpers

J1	OUT1 type (open: 4-20 mA; closed 0-10 V)
J2	OUT2 type (open: 4-20 mA; closed 0-10 V)
X6	Reset Modbus network parameters to default

X4 terminals

OUT1	4-20 mA / 0-10 V output
OUT2	4-20 mA / 0-10 V output
0V	0 V / 24 VAC Neutral (optional)
A	RS485 A / Data +
B	RS485 B / Data -
+U	+24 VDC / 24 VAC Phase (optional)

X5 terminals (optional)

L	90...265 VAC Phase
N	90...265 VAC Neutral
RE1 NO	Relay 1, normally open terminal
RE1 COM	Relay 1, common terminal
RE2 NO	Relay 2, normally open terminal
RE2 COM	Relay 2, common terminal



Remote probe

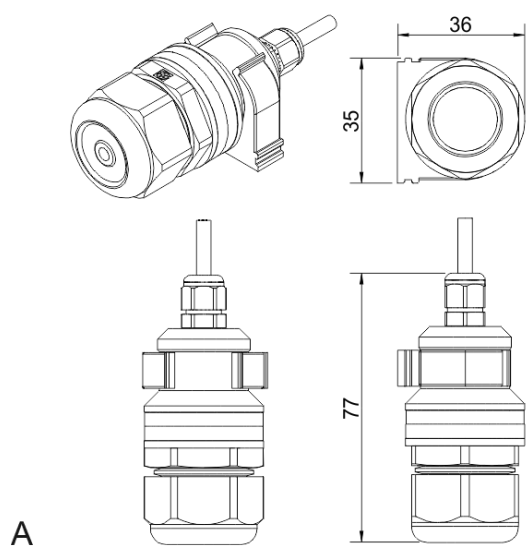

A

Wall mount remote probe with fixing clamp
(default version)

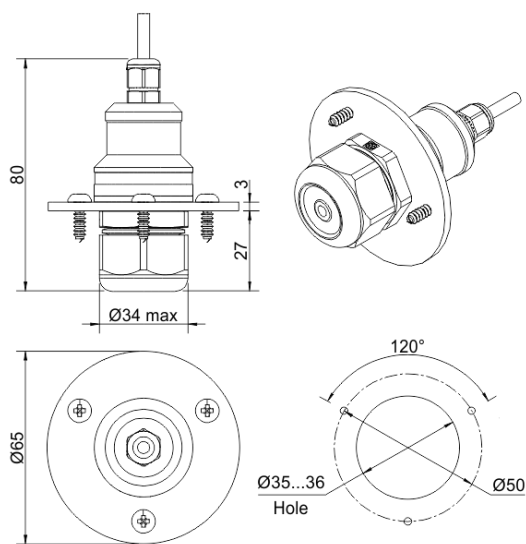

B

Remote probe with rubber flange and three
self-tapping screws (on request)

