



# Combustible Gas Transmitter E2615-LEL



## Features

- High long-term stability
- User selectable output 4-20 mA / 0-10 V
- Range of compact wall mount enclosures
- Low cost for volume HVAC applications

## Specifications

Calibration	Methane, propane, butane, hydrogen
Sensor type	Catalytic Bead (Pellistor)
Sampling method	Diffusion
Detection range	0-100% LEL
Response time T90	< 10 s
Sensor protection	Microporous PTFE dust filter
Warm-up time	≤ 1 min
Analog output	4-20 mA / 0-10 V, user settable
Power supply	24 VDC ± 20%
Power consumption	< 1 W
Sensor lifetime	> 3 years *in an appropriate residential or light commercial applications
Sensitivity drift	< ± 5% / year *in an appropriate residential or light commercial applications
Indoors enclosure IP20 version	White, ivory or black ABS plastic, wall mount, protection class IP20
Weatherproof enclosure IP65 version	Grey ABS plastic, wall mount, protection class IP65
Dimensions	H71 × W71 × D27 mm (IP20 version) H70 × W80 × D36 mm (IP65 version)
Operating conditions	-40...+70 °C <95% RH pressure 0,9...1,1 atm
EMC Emissions	To EN 61000-6-3, EN 61326-1
EMC Immunity	To EN 61000-6-1, EN 61000-6-2

## IP65 Enclosures

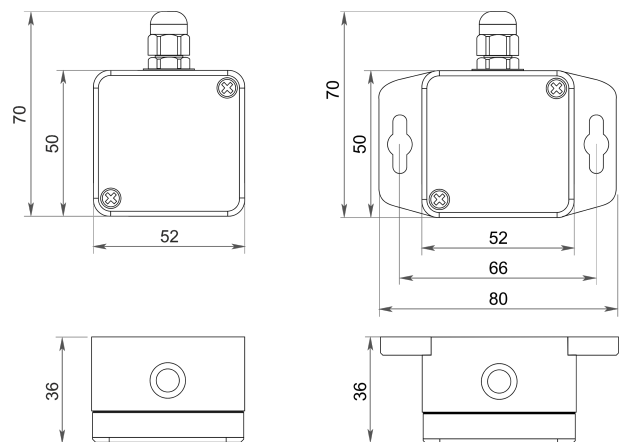

## IP20 Enclosures

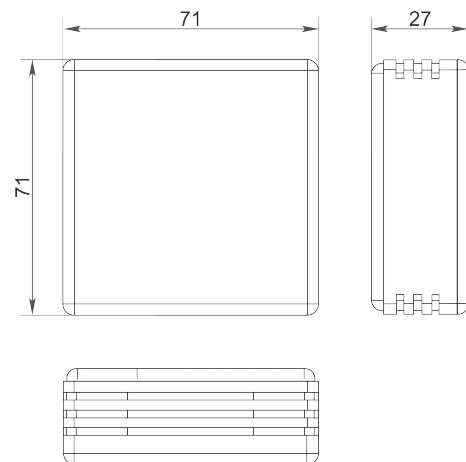

## Connection diagrams

### 3-wire 4-20 mA output

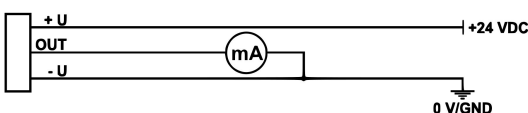

### 3-wire 0-10 V output

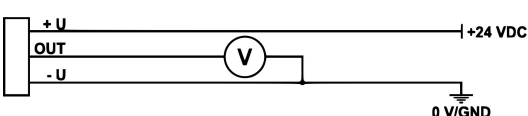

Ask for other versions or custom designed products

