



Indigo500MIK Meteorological Installation Kit



Features

- Outdoor installation kit for Indigo500 Series transmitters
- Supports wall and pole mounting
- Delivered pre-assembled according to selected options
- DTR502 Solar Radiation Shield option prevents temperature measurement error
- DTS1 Weather Shield option prevents a microclimate from forming around a heated probe
- SPH10 Static Pressure Head option eliminates pressure variations caused by wind

The Indigo500MIK Meteorological Installation Kit enables Vaisala Indigo500 Series transmitters to obtain professional grade outdoor measurements of environmental parameters. The kit is delivered pre-assembled with the selected options, with or without measurement equipment.

Essential for critical weather measurements

Outdoor installation of measurement instruments must be done properly to avoid common sources of measurement error, and to ensure long service life. The Indigo500MIK Meteorological Installation Kit is designed to enable Indigo500 Series transmitters and compatible measurement probes to obtain reliable measurements in challenging weather conditions. The kit is recommended for use with the HMP3 and HMP7 humidity and temperature probes, and the TMP1 temperature probe.

True humidity readings in condensing conditions

In weather observations dew formation makes reliable humidity measurement difficult. When dew has formed on the humidity sensor, it is impossible to obtain a true reading until the dew evaporates. Obtaining a true humidity

reading is particularly important in traffic safety, at airports, and at sea. It is essential, for example, in fog and frost prediction.

Combining an Indigo500 Series transmitter with a HMP7 and TMP1 probes provides a solution to the problem. HMP7 utilizes probe heating for condensation prevention. When the probe head is heated, risk of dew formation on the sensor is greatly reduced. When combined with accurate temperature measurement from TMP1 probe, the Indigo500 transmitter can calculate the ambient relative humidity precisely in all conditions.

Open shield prevents microclimates

Traditional solar radiation shields are not optimal for use with heated probes, as sleet or snow can accumulate on the shield. This may prevent proper air circulation and create a humid microclimate around the probe head until the snow melts.

DTS1 Weather Shield option provides the heated HMP7 probe with appropriate protection that prevents the formation of a microclimate. The shield is open at the bottom to ensure steady air circulation to the sensor even in calm weather.

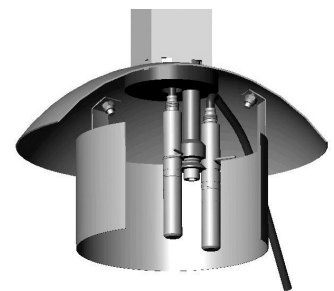

For calibration, a portable HMP77 reference probe is easy to attach beside the HMP7 probe head.

Technical data

DTR502 Solar Radiation Shield (option) for humidity and temperature probes

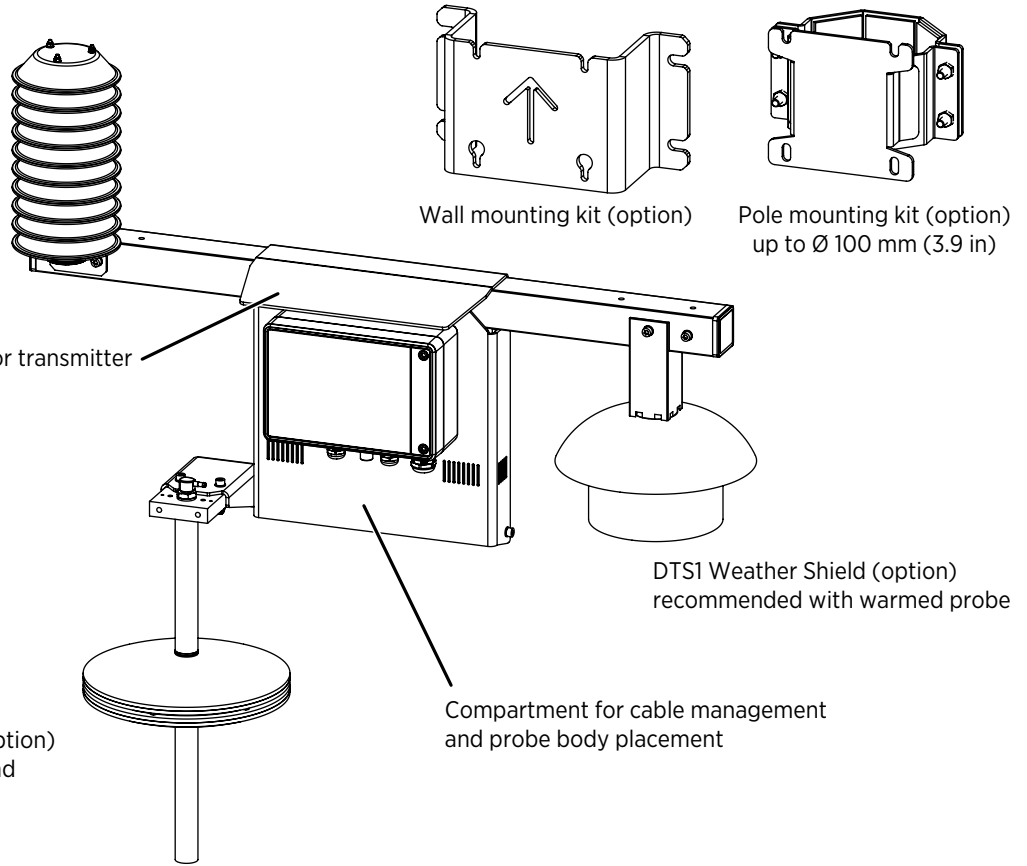

SPH10 Static Pressure Head (option) for minimizing the effect of wind on pressure measurement

Specifications

Compatible transmitters	Indigo510, Indigo520, HMT370EX
Compatible solar radiation shields	DTR502, DTR13, DTR250
Weather shield for heated probe	DTS1 ¹⁾
Static pressure head	SPH10 ¹⁾
Weight of mounting plate, probe compartment, and support bar	1.5 kg (3.3 lb)
Material of mounting plate, probe compartment, and support bar	Anodized marine grade aluminum

¹⁾ Attachment requires an adapter that is included when ordering the mounting kit with this option.

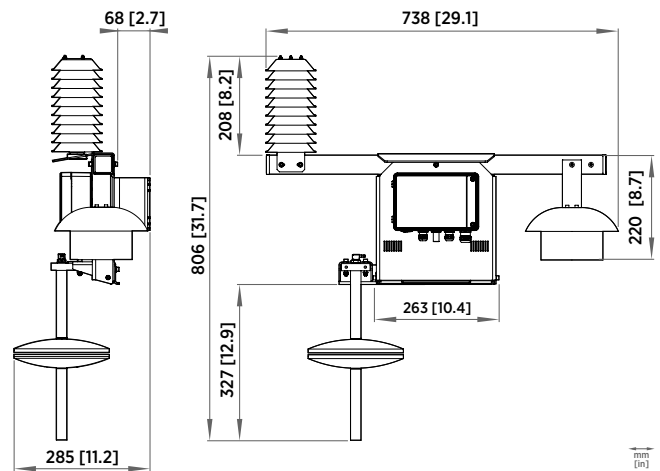

Indigo500MIK dimensions with wall mounting kit



www.vaisala.com

Published by Vaisala | B212436EN-B © Vaisala 2022

All rights reserved. Any logos and/or product names are trademarks of Vaisala or its individual partners. Any reproduction, transfer, distribution or storage of information contained in this document is strictly prohibited. All specifications – technical included – are subject to change without notice.