

VCC200

Capacitance Vacuum Transducer Absolute Pressure 200 to 0.1 mbar

The VCC200 capacitance vacuum transducer is used for measuring absolute pressure with high accuracy and independent of gas type even below 20 mbar.

Due to its durable ceramic sensor it is nearly insensitive to dirt and contamination.



Typical Applications

- Chemical process engineering
- Vacuum insulations
- Evacuation and filling
- Analysis instruments
- Packing machines
- Medical technology
- Appliance engineering
- Vacuum furnaces
- Lamp production
- Vacuum drying

Benefits

- Excellent accuracy
- High resolution
- Corrosion resistant aluminum oxide ceramic sensor
- Measurement is independent of gas type
- High reliability
- Short response time
- Temperature compensated
- Insensitive against contamination
- Suitable for Thyracont display and control unit VD6
- Standardized output signal 4 - 20 mA (two wire), linear
- Easy connection to PLCs and other system controllers
- Designed for industrial applications
- Robust metal housing with protection class IP54
- Vacuum connection over a stainless steel small flange DN 16 ISO-KF with G1/4 female thread



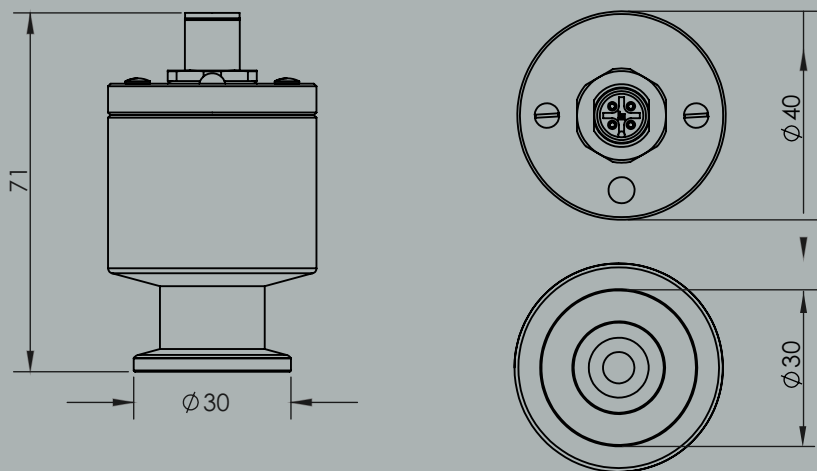

Dimensions in mm

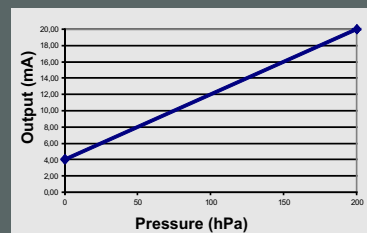

$$I_{out} \text{ (mA)} = (p \text{ (hPa)} / 12.5) + 4.0$$

$$p \text{ (hPa)} = 12.5 (I_{out} \text{ (mA)} - 4.0)$$

Technical Data

Measuring Principle	Capacitive, absolute pressure, independent of gas type
Materials In Contact With Vacuum	Stainless steel 1.4305, Al ₂ O ₃ ceramic, FKM
Measurement Range	200 - 0.1 mbar (150 - 0.1 Torr), max. overpressure 6 bar absolute
Accuracy	± 0.25 % full scale (f.s.), linearity, hysteresis, repeatability
Temperature Coefficient	± 0.04 % f.s. / 10 K
Response Time (10...90%)	< 120 ms
Power Supply	9 - 30 VDC
Electrical Connection	M12, 5-pole, male, lockable
Operating Temperature	+5...+60°C, relative humidity max. 80% at 25 °C
Storage Temperature	-40...+70°C
Output Signal	4 - 20 mA, two wire (linear) max. loop resistance: $R_{max} [\Omega] = (\text{Supply Voltage [V]} - 9) / 0.02$
Vacuum Connection	Stainless steel small flange DN 16 ISO-KF with G1/4 female thread
Protection Class	IP54 (with suitable counter plug)
Weight	Approx. 170 g

Product Codes

- **VCC200MA4**
Capacitance transducer
200 - 0.1 mbar with DN 16 ISO-KF
flange; G1/4 female thread;
output 4 - 20mA (two wire)

Accessories:

- **VD81SW1**
Hose nozzle 6 to 8 mm, brass,
nickel plated
- **XB0500004**
Mating plug, 5pole f. VCC200MA4
- **W05090002**
Measuring cable, for VD6, shielded,
2 m
- **W05090006**
As W05090002, 6 m