

## Tachometer CT 50

### KEY POINTS

- Easy to use
- HOLD function
- Built-in probe
- Auto shut-off : 20 minutes

### FEATURES OF THE HOUSING

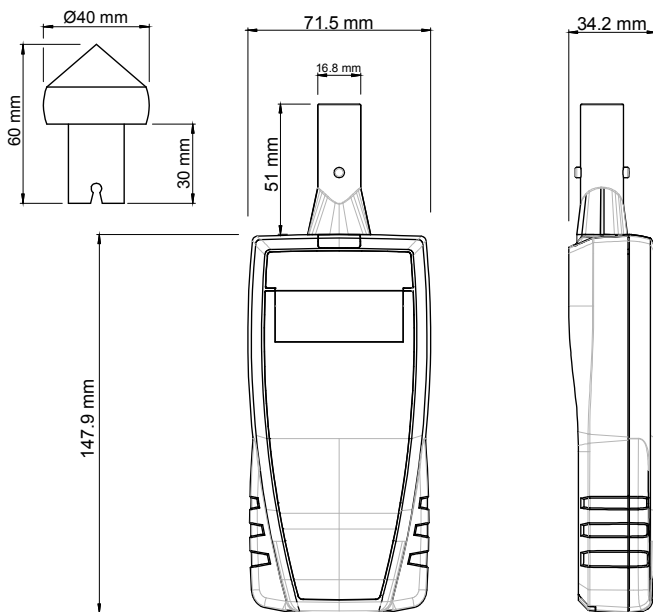

**Material :** ABS

**Protection :** IP54

**Display :** 1 line  
LCD 1 x 5 digits  
Size : 50 x 20 mm

**Height of digits :**  
Values : 9.2 mm  
Units : 4.7 mm

**Weight :** 200 g (with batteries)



### TECHNICAL FEATURES

Parameter	Optical velocity	Contact velocity
<b>Measuring units</b>	rpm	rpm, m/min, ft/min, in/min, m/s
<b>Measuring Range</b>	From 0 to 60 000 rpm	From 0 to 20 000 rpm
<b>Accuracy*</b>	From 60 to 10 000 rpm : $\pm 0,3\%$ of reading $\pm 1$ rpm From 10 001 to 60 000 : $\pm 30$ rpm	From 30 to 3000 rpm : $\pm 1\%$ of reading $\pm 1$ rpm
<b>Resolution</b>	1 rpm	1 rpm
<b>Measuring elements</b>	Phototransistor, sighting distance max. 40cm	ETC Adapter positioned on optical probe
<b>Conditions of use (°C/%RH/m)</b>	From 0 to +50 °C. In non-condensing conditions. From 0 to 2000 m.	
<b>Storage temperature</b>	From -20 to +80 °C	
<b>Power supply</b>	4 batteries AAA LR03 1.5 V	
<b>Battery life</b>	20 hours	
<b>European directives</b>	2014/30/EU EMC ; 2014/35/EU Low Voltage ; 2011/65/EU RoHS II ; 2012/19/EU WEEE	

## SUPPLIED WITH

Instruments are supplied with an adjustment certificate, a reflective tape, a contact tip and a soft case.



## ACCESSORIES

- Calibration certificate
- Transport case
- Magnetic protective housing



**Only the accessories supplied with the device must be used.**



## MAINTENANCE

We carry out calibration, adjustment and maintenance of your instruments to guarantee a constant level of quality of your measurements. As part of Quality Assurance Standards, we recommend you to carry out a yearly checking.

## GUARANTEE

Instruments have 1-year guarantee for any manufacturing defect (return to our After-Sales Service required for appraisal).

## PRECAUTIONS FOR USE

Please always use the device in accordance with its intended use and within parameters described in the technical features in order not to compromise the protection ensured by the device.

## USE OF THE INSTRUMENT

### Take a measurement

- Switch on the instrument by pressing briefly on **“On/Off/Hold”**.  
*The instrument displays its name “CT50” then the measurement.*

### Hold the measurement

During measurement :

- Press briefly on **“On/Off/Hold”** to hold measurement.  
*“Hold” appears on the screen and the measurement is fixed.*
- Press again briefly on **“On/Off/Hold”** to exit the Hold function.

### Select measurement

During measurement :

- Press briefly on **“Select”** to select the desired unit of measurement.

### Select the type of velocity (contact or optical)

The instrument is on.

- Pressing longer on **“Select”**.  
*“Cont” or “Optic” flash.*
- Press briefly on **“Select”** to select contact velocity **“Cont”** or optical velocity **“Optic”**.
- Pressing longer on **“Select”** to confirm the type of velocity.

### How to change batteries

- Remove the front part at the back of the instrument.
- Replace used batteries by new batteries AAA LR03 1.5 V.
- Replace the front.

Auto shut-off : the instrument switches off if not used during 20 minutes.



Once returned to KIMO, required waste collection will be assured in the respect of the environment in accordance with European guidelines relating to WEEE.

[www.kimo.fr](http://www.kimo.fr)

Distributed by :



EXPORT DEPARTMENT

Tel : + 33. 1. 60. 06. 69. 25 - Fax : + 33. 1. 60. 06. 69. 29

e-mail : [export@kimo.fr](mailto:export@kimo.fr)

