

VCP63

Vacuum Transducer Absolute Pressure 1000 to 5×10^{-4} mbar

The Pirani sensor in the VCP63 works with the patented impulse ramp principle.

The VCP63 has an optimized temperature compensation, which leads to higher accuracy and excellent stability.

Analog, logarithmic output signal



Typical Applications

- Analysis instruments
- Applications with corrosive gases
- Coating plants
- Vacuum ovens
- Freeze drying
- Chemical engineering
- Safety circuits in vacuum systems and monitoring of fore vacuum
- Vacuum centrifuges

Benefits

- Suitable for corrosive media
- High reliability
- Compact design for industrial applications
- High resolution, also in the rough vacuum range
- Excellent reproducibility
- High chemical resistance with platinum rhodium filament
- Durable, elastic Pirani helix filament
- Stable measurements due to optimized temperature compensation
- Suitable for UHV applications due to the robust metal sealed stainless steel sensor
- Filament protected by a metal screen provides good resistance against oil and solvent vapors
- Suitable for Thyracont 2 channel display and control unit VD12
- Precise push button digital adjustment on zero pressure and atmosphere
- Logarithmic standard output 2.2 - 8.5 V
- Easy system integration and connection with PLCs, wide supply voltage range
- Rugged, EMI-proof metal housing
- Vacuum connection using stainless steel small flange DN 16 ISO-KF



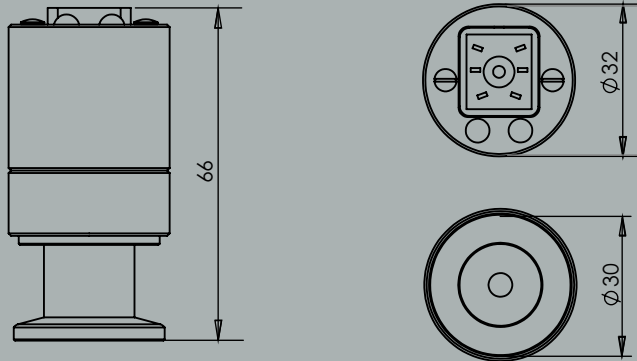

Dimensions in mm

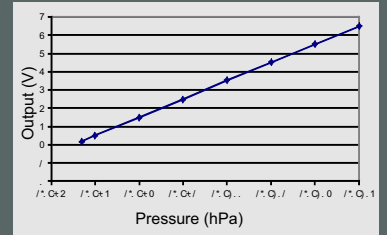

$$V_{\text{out}} (\text{V}) = \log (p(\text{hPa})) + 5.5$$

$$p (\text{hPa}) = 10^{(V_{\text{out}}(\text{V}) - 5.5)}$$

Technical Data

Measuring Principle	Heat conduction (Impulse Pirani), depending on gas type
Materials In Contact With Vacuum	Stainless steel 1.4307, nickel, glass, filament: platinum-rhodium
Measurement Range	1000 - 5×10^{-4} mbar ($750 - 5 \times 10^{-4}$ Torr), max. overpressure 10 bar absolute
Accuracy	1000 - 10 mbar: $\lt \pm 30\%$ from reading 10 - 1×10^{-2} mbar: $\lt \pm 10\%$ from reading $\lt 1 \times 10^{-2}$ mbar: \lt factor 2
Repeatability	1×10^{-2} : $\pm 5\%$ from reading
Response Time	Max. 200 ms
Voltage Supply	15 - 30 VDC
Electrical Connection	Hirschmann, 6 pole, male, lockable
Power Consumption	Max. 1.5 W with 24 VDC supply voltage
Operating Temperature	+5...+60°C
Storage Temperature	-20...+70°C
Max. Bake Out Temperature	150°C at the flange
Output Signal	2.2 - 8.5 VDC, logarithmic, 1 V / decade load resistance $\gt 10 \text{ k}\Omega$
Vacuum Connection	Small flange DN 16 ISO-KF
Protection Class	IP40
Weight	Approx. 120 g

Product Codes

- VCP63MV**
 Pirani transducer, 1000 to 5×10^{-4} mbar, with DN 16 ISO-KF connection; output 0 - 10 V logarithmic

Accessories:

- XBo600002**
 Mating plug, 6pole, for VCP63MV
- Wo606002**
 Measuring cable for VCP63MV with VD12, shielded, 2 m
- Wo606006**
 As Wo606002, 6 m